

Product Summary

$V_{(BR)DSS}$	$R_{DS(on)TYP}$	I_D
100V	3.0Ω@10V	0.28A
	3.2Ω@4.5V	

Feature

- Surface Mount Package
- High Density Cell Design for Extremely Low RDS(ON)
- Voltage Controlled Small Signal Switch
- Rugged and Reliable
- ESD protected Gate

Application

- Small Servo Motor Controls
- Power MOSFET Gate Drivers
- Switching Application

MARKING:

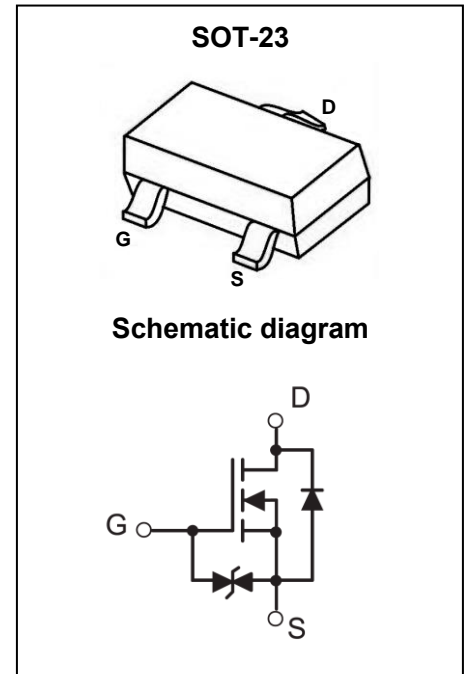
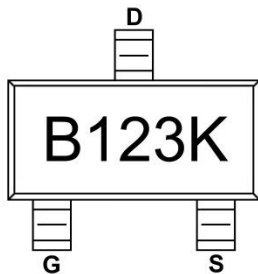

ABSOLUTE MAXIMUM RATINGS ($T_A = 25^\circ\text{C}$ unless otherwise noted)

Parameter	Symbol	Value	Unit
Drain-Source Voltage	V_{DS}	100	V
Gate-Source Voltage	V_{GS}	±20	V
Continuous Drain Current ^{1,2}	I_D	0.28	A
Pulsed Drain Current ($t_p=10\mu\text{s}$)	I_{DM}	1.12	A
Power Dissipation	P_D	0.78	W
Thermal Resistance from Junction to Ambient ^{1,2}	$R_{\theta JA}$	160	$^\circ\text{C/W}$
Operating Junction and Storage Temperature Range	T_J, T_{STG}	-55~ +150	$^\circ\text{C}$

MOSFET ELECTRICAL CHARACTERISTICS ($T_A = 25^\circ\text{C}$ unless otherwise noted)

Parameter	Symbol	Test Condition	Min	Type	Max	Unit
Off Characteristics						
Drain-Source Breakdown Voltage	$V_{(BR)DSS}$	$V_{GS} = 0V, I_D = 250\mu A$	100			V
Zero Gate Voltage Drain Current	I_{DSS}	$V_{DS} = 80V, V_{GS} = 0V$			1	μA
Gate-Body Leakage Current	I_{GSS}	$V_{GS} = \pm 20V, V_{DS} = 0V$			± 5	μA
On Characteristics³						
Gate Threshold Voltage	$V_{GS(th)}$	$V_{DS} = V_{GS}, I_D = 250\mu A$	1	1.4	3	V
Drain-Source On-Resistance	$R_{DS(on)}$	$V_{GS} = 10V, I_D = 0.17A$		3.0	4.5	Ω
		$V_{GS} = 4.5V, I_D = 0.17A$		3.2	6.0	
Forward Transconductance	g_{FS}	$V_{DS} = 10V, I_D = 0.17A$		0.47		S
Dynamic Characteristics						
Input Capacitance	C_{iss}	$V_{DS} = 45V, V_{GS} = 0V, f = 1MHz$		29		pF
Output Capacitance	C_{oss}			4		
Reverse Transfer Capacitance	C_{rss}			2		
Switching Characteristics						
Turn-On Delay Time	$t_{d(on)}$	$V_{GS} = 10V, V_{DD} = 30V, I_D = 0.17A,$ $R_G = 50\Omega$		7		ns
Turn-On Rise Time	t_r			6		
Turn-Off Delay Time	$t_{d(off)}$			10		
Turn-Off Fall Time	t_f			9		
Total Gate Charge	Q_g	$V_{DS} = 10V, I_D = 0.17A, V_{GS} = 10V$		1.5		nC
Gate-Source Charge	Q_{gs}			0.16		
Gate-Drain Charge	Q_{gd}			0.2		
Diode Characteristics						
Diode Forward Voltage ³	V_{SD}	$I_S = 0.17A, V_{GS} = 0V$		0.8	1.3	V

Notes :

1. $R_{\theta JA}$ is measured with the device mounted on 1 in² FR4 board with 1oz. single side copper, in a still air environment with $T_A = 25^\circ\text{C}$.
2. $R_{\theta JA}$ is measured in the steady state
3. Pulse test : Pulse width $\leq 380\mu s$, duty cycle $\leq 2\%$.

Typical Characteristics

Output Characteristics

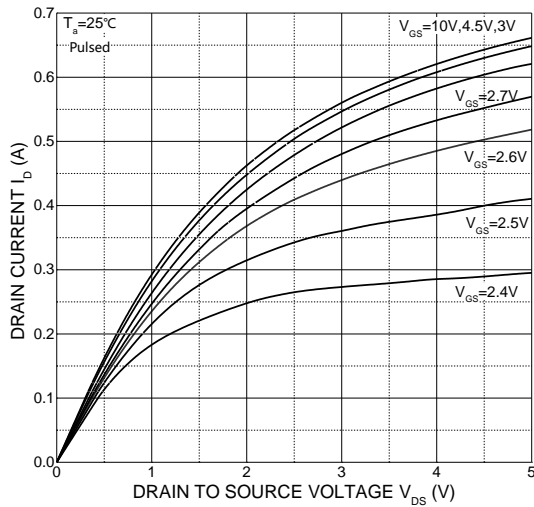

Transfer Characteristics

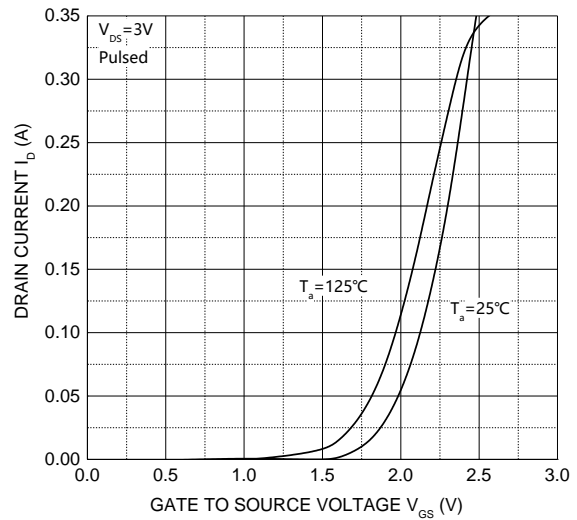

$R_{DS(ON)} - I_D$

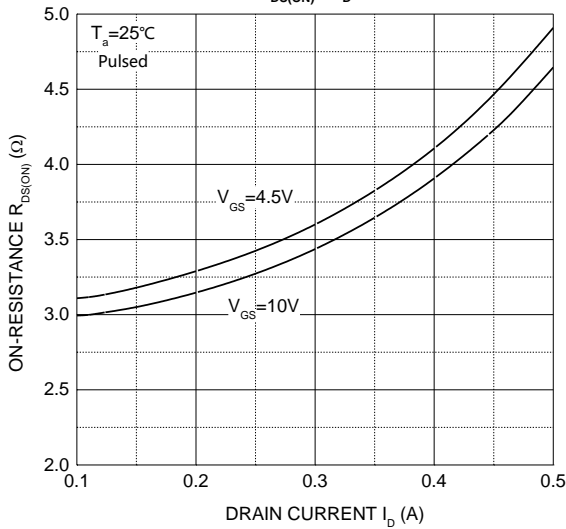

$R_{DS(ON)} - V_{GS}$

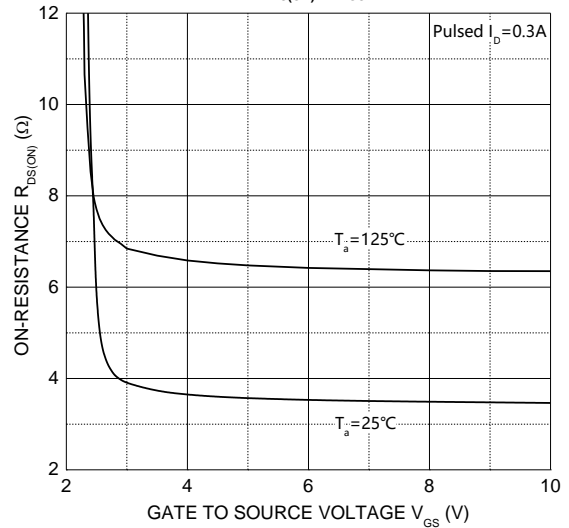

$I_S - V_{SD}$

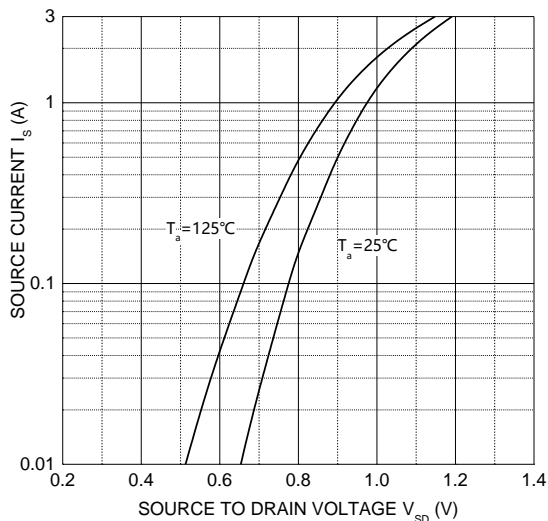

Threshold Voltage

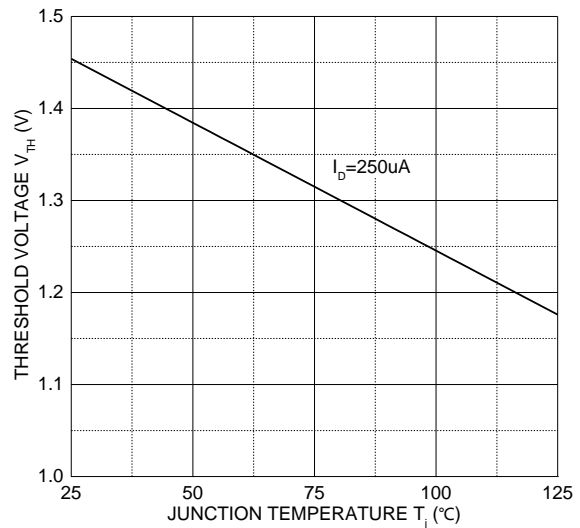

SOT-23 Package Information

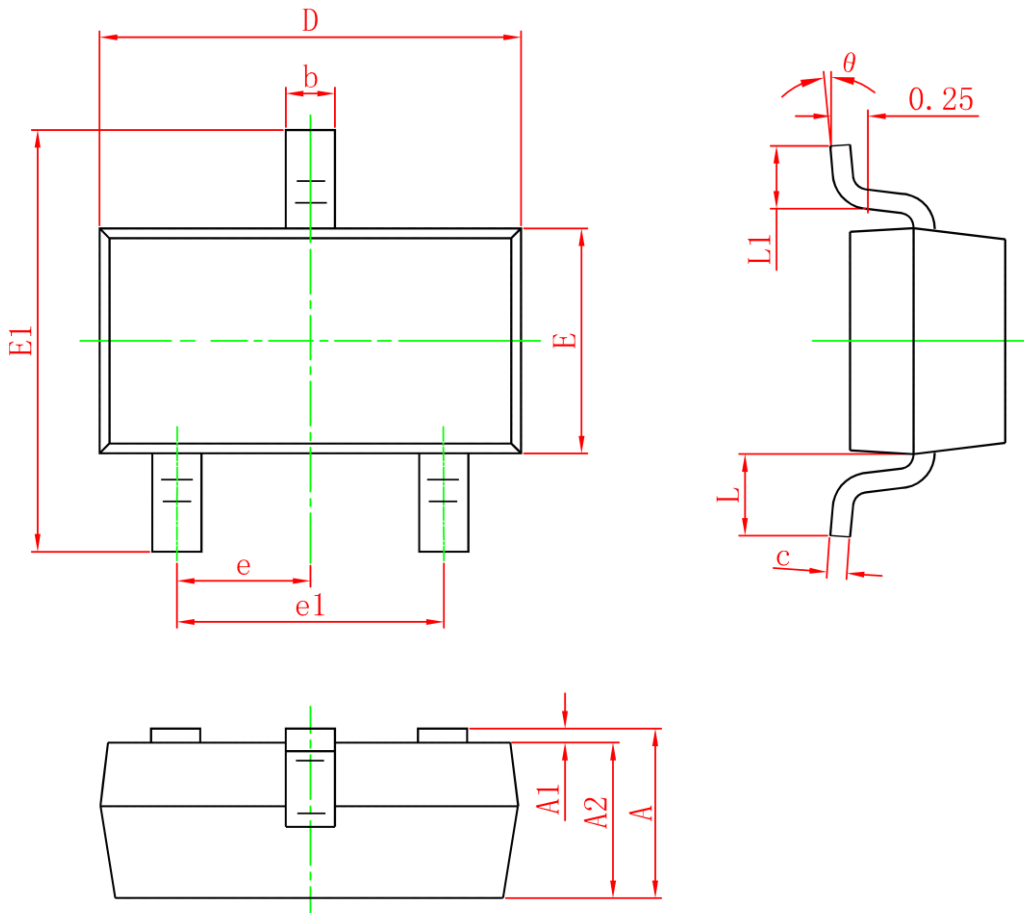

Symbol	Dimensions In Millimeters		Dimensions In Inches	
	Min.	Max.	Min.	Max.
A	0.900	1.300	0.035	0.051
A1	0	0.100	0	0.004
A2	0.900	1.200	0.035	0.047
b	0.300	0.550	0.012	0.022
c	0.080	0.158	0.003	0.006
D	2.800	3.000	0.110	0.118
E	1.150	1.500	0.045	0.059
E1	2.200	2.700	0.087	0.106
e	0.950TYP		0.037TYP	
e1	1.800	2.000	0.071	0.079
L	0.550REF		0.022REF	
L1	0.300	0.500	0.012	0.020
θ	0°	8°	0°	8°

Attention:

- GreenPower Electronics reserves the right to improve product design function and reliability without notice.
- Any and all semiconductor products have certain probability to fail or malfunction, which may result in personal injury, death or property damage. Customer are solely responsible for providing adequate safe measures when design their systems.
- GreenPower Electronics products belong to consumer electronics or other civilian electronic products.